



RENTAL PACKAGE 30 Ton Air Conditioner

Cat® air conditioning units are self-contained and provide conditioned air for outdoor rental applications. Units are sound attenuated and are equipped with screw-type compressors which allow for cold starting—no preheat required. Units feature rental friendly controls to meet the needs of the non-technical operator. Units designed in accordance with industry guidelines and third party safety and quality standards.

TECHNICAL SPECIFICATIONS

Model.....	Stealth 30	Total shipping weight.....	3,900 lbs
Dimensions		Duct connections.....	19"
Length.....	8'	Filter (reusable).....	2" (30% efficient)
Width.....	5'5"	Power supply.....	460 volt/3 phase/ 60 HZ with ground
Height.....	8'6"		

TECHNICAL DATA

Total full load or running load	67 amps
System Control Remote Temperature Control Discharge air temperature control Return air temperature control	Standard Standard Standard
Fan Data Design air flow/maximum air flow Design total static pressure Fan type Fan control Motor power/speed	10,000 cfm 3.25 in wg Centrifugal VFD 10 hp/862-1725 rpm
Cooling Data Design capacity Entering air temp (dry bulb/wet bulb) Leaving air temp (dry bulb/wet bulb) Coil construction Rows Fins per inch Low ambient control	30 tons (2 Stage) 90/70 °F 63.5/59.6 °F Copper Tube/Aluminum fins 3 10 Hot gas bypass
Heating Data (Optional) Type Capacity Heating	Electric 150kW 500 MBH
Compressor Data Type	High Efficiency Scroll

DIMENSIONS

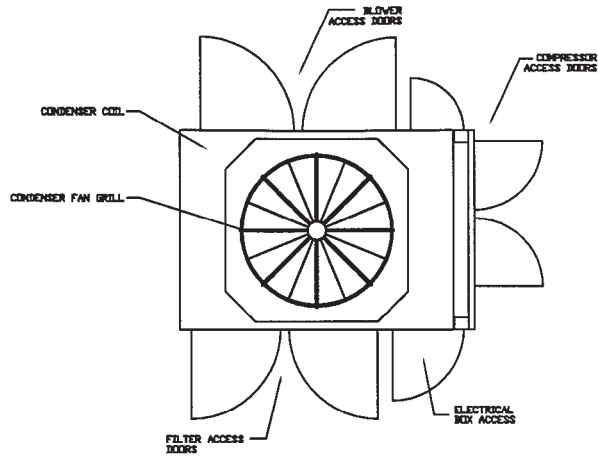

PLAN VIEW

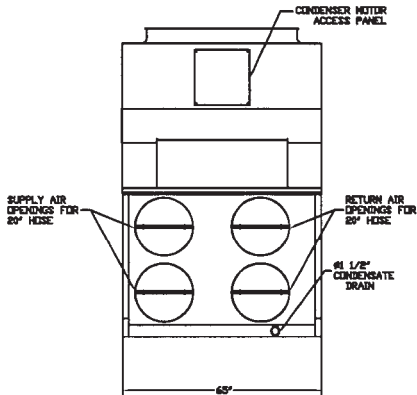

END VIEW 'PLENUM END'

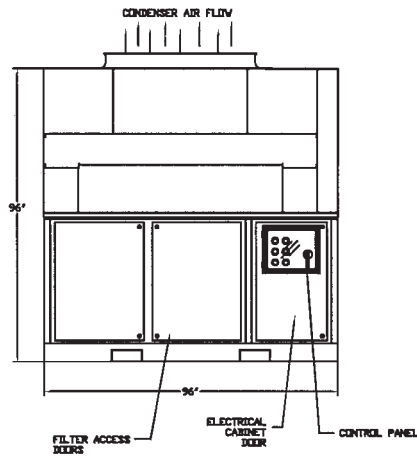

ELEVATION VIEW 'CONTROL SIDE'

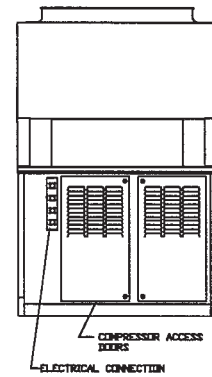

END VIEW 'COMPRESSOR END'

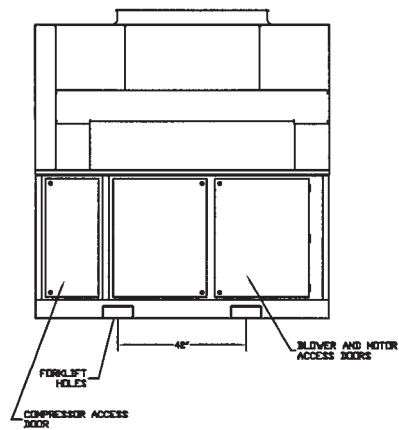

ELEVATION VIEW 'BLOWER SIDE'

Consult your Caterpillar representative for more details.

©2014 Ohio CAT
All rights reserved.
Materials and specifications are subject to change without notice.