

**RENTAL UNIT
200 Ton Air Cooled Chiller**

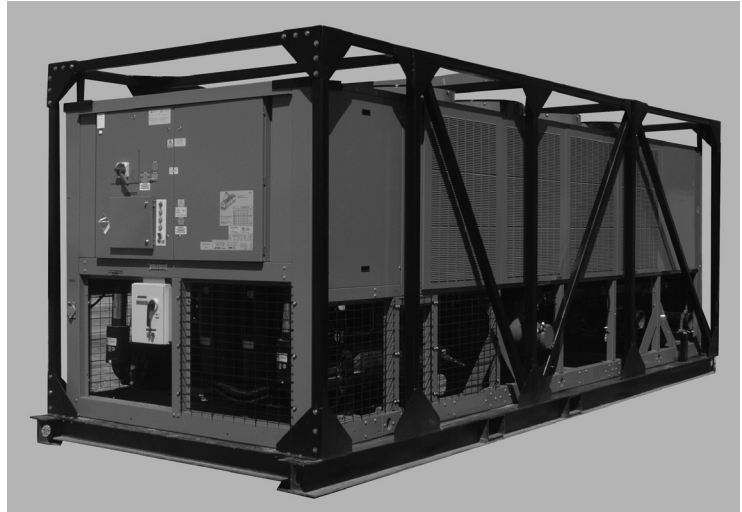

SPECIFICATIONS:

Model.....207 Ton Air Cooled Chiller
 Dimensions
 Length.....300"
 Width.....92"
 Height.....105"
 Rigging Weight.....17,882 lbs.
 Operating Weight.....18,800 lbs.

APPLICATIONS:

- Alkylation (Alky) Cooling
- Wet Gas Compressor Cooling
- Concrete Cooling
- Dense Air Injection
- Environmental Control
- Plastic Production Processes
- Turbine Inlet Cooling
- Waste Water Treatment

TECHNICAL DATA

<p>Evaporator Data EWT (°F) LWT (°F) Design Flow Rate (gpm) Pressure Drop (ft.) Fluid Water Volume (gal.)</p>	<p>54.0 44.0 516.0 14.4 Water 140.0</p>
<p>Condenser Data Ambient Temp. (°F)</p>	<p>95.0</p>
<p>Electrical Data Volts/Ph/Hz Min. Circuit Ampacity Recommended Fuse/CB Rating Max. Dual Element Fuse Size (Amps)</p>	<p>460/3/60 373 450 500</p>
<p>Min/Max Flow GPM</p>	<p>Min Flow 180 Max Flow 800</p>
<p>Compressor Type:</p>	<p>2 Variable-Drive Screw</p>
<p>General Capacity Refrigerant Chilled Water/Brine Temperature Range</p>	<p>215.3 Tons R134A 20°F</p>

Consult your Ohio CAT representative for more details.

©2014 Ohio CAT
 All rights reserved.
 Materials and specifications are subject to change without notice.

